



## Operating Manual

Intrinsically safe barcode scanner

iSCAN100



# Document number 316288 Issue 1

Document Number **316288** (See Last Page for Revision Details)

©2006 Extronics Limited. This document is Copyright Extronics limited.

Extronics reserve the right to change this manual and its contents without notice, the latest version applies.

---

# Contents

---

1	Introduction.....	4
2	Safety Information and Notes .....	5
3	Installation .....	6
3.1	PS2 Installation .....	6
3.2	RS232 Installation.....	7
3.3	Optional Accessory Kits .....	9
3.3.1	Optional iSCAN100 Extender Junction Box – Part number iSCAN100JB .....	9
	Contains:.....	10
4	Operation.....	11
4.1	How to use the iSCAN100 .....	11
4.2	Audible Indicators .....	12
4.3	Visual Indicators.....	13
4.4	Failure Modes .....	14
4.5	Programming Modes.....	15
4.6	Serial Programming .....	16
4.7	Upgrading The Flash ROM Firmware .....	19
5	Depth of Field and IR Activation .....	20
6	Troubleshooting Guide .....	22
7	Intended Purpose Usage.....	26
8	Technical Data.....	28
9	Certification .....	30
10	Booklet Revision Notes .....	32

---

# 1 Introduction

---

The iSCAN100 is the latest development in barcode scanning technology for Zone 1 and Zone 2 hazardous areas. The unit offers a very high specification but at an affordable price as it is based on the very latest ideas in Ex protection technology.

The scanner is ergonomically designed in an IP55 pistol grip housing that is comfortable to use for an operator, even when wearing gloves. The housing has a rubber protective shield to protect it from dropping on to hard floors.

Supplied with a spiral cable the iSCAN100 can be connected to systems by a PS2 keyboard wedge or an RS232 serial interface. Most popular barcode symbologies are supported by the built-in decoder providing the PC or operator terminal with ASCII data.

A friction free scanning mechanism is designed to be highly reliable and give a long service life. Scanning 72 times per second at up to 33 cm away from the barcode makes this unit very practical to use for demanding applications.

Each type is rigorously checked and tested by Extronics to ensure conformity to the ATEX standards and approvals.

---

## 2 Safety Information and Notes

---

Keep this user manual safe and in the vicinity of the device. All persons who have to work on or with the device should be advised on where the manual is stored.

**Warning** Installation to be by skilled electricians and instructed personnel in accordance with national legislation, including the relevant standards and, where applicable, in accordance with IEC 79.17 on Electrical Apparatus for Explosive Atmospheres.

**Warning!** The iSCAN100 can be used in gas zones 2 & 1 BUT NOT 0!

**Warning!** The iSCAN100 must only be connected and powered from a suitably approved intrinsically safe interface .

**Important** The technical data indicated on the iSCAN100 must be observed.

**Important** Changes in the design and modifications to the equipment are not permitted.

**Important** The iSCAN100 shall be operated as intended and only in undamaged and perfect condition.



**DANGER! RADIATION FROM LIGHT EMITTING DIODES DO NOT LOOK INTO THE BEAM, DO NOT POINT THE BEAM AT PERSONS OR ANIMALS**

Light power <1mW

Class 1 Laser product

## 3 Installation

### 3.1 PS2 Installation

For the PS2 version while power is off plug the male PS2 connector on the iSCAN100 cable into the female socket on the Extronics iSOLATE100 or similar intrinsically safe interface.

Examples and Connection details for the PS/2 can be found in Diagram 3.1 below

#### Examples iSCAN100 PS/2 scanner connections using the iSOLATE100 Ex01: Example 1 Without Keyboard.

Diagram 3.1

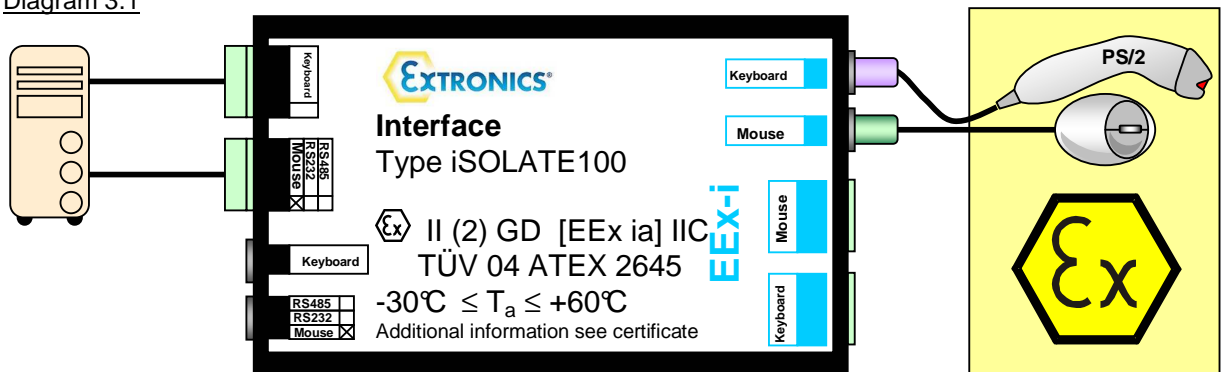

The iSCAN100 PS/2 scanner can be connected on the hazardous side instead of the keyboard. In this configuration the mouse may or may not be connected.

Since a scanner does not answer to the PC's request the PC might switch off the keyboard line after booting. In this case please cancel the keyboard test in the BIOS settings of your PC or wire a keyboard in parallel to the scanner.

#### Example 2 With Keyboard.

Diagram 3.2

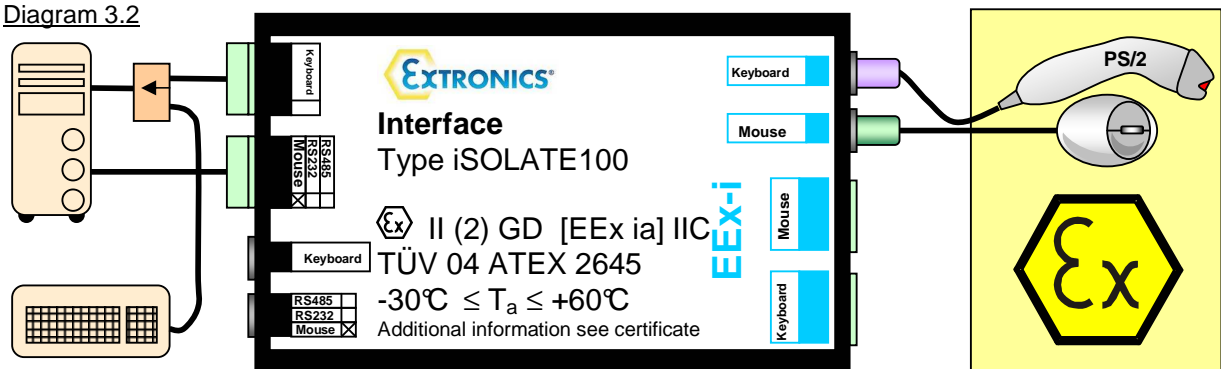

Furthermore you may connect a keyboard with the safe side of iSOLATE100 using its built-in keyboard wedge. Please refer to version Ex02.

## iSCAN100 PS2 Connection Details

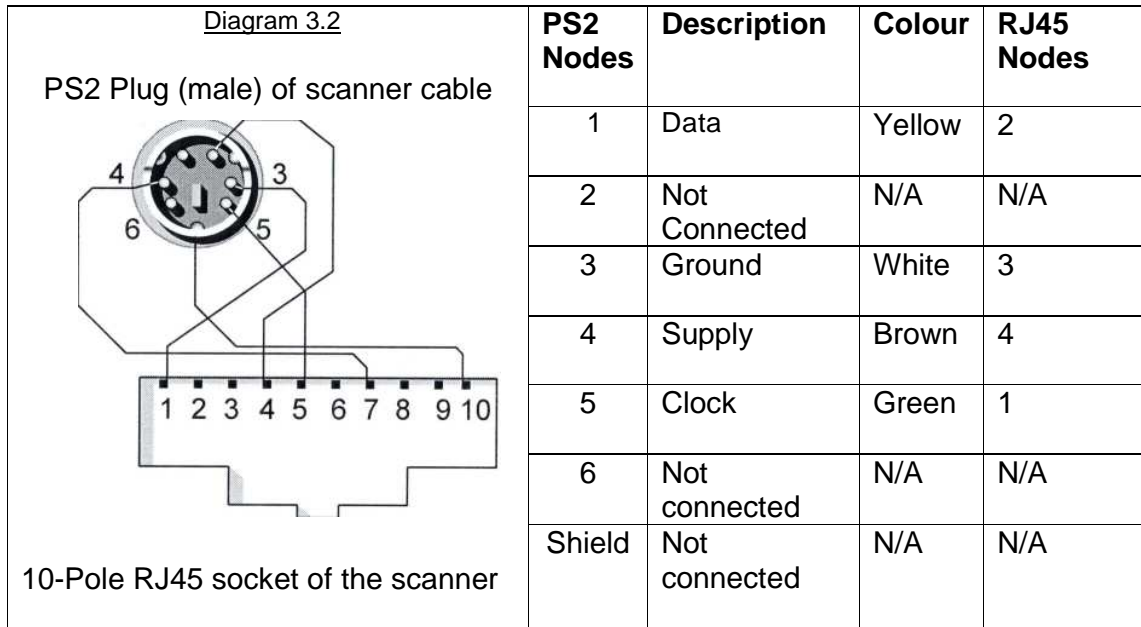

Note: If your iSCAN100 has a PS2 plug fitted when purchased cable colours may vary from those indicated in this diagram

### 3.2 RS232 Installation

For the RS232 version while power is off wire the cable to the terminals on the ISOLATE100 or similar intrinsically safe interface.

Examples and Connection details for the PS/2 can be found in Diagram 4.2 below

#### Version Ex03

Diagram 3.4

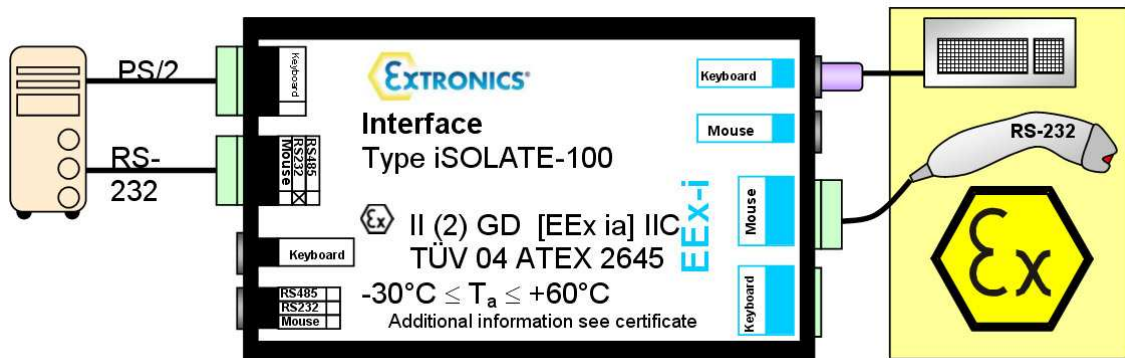

The iSOLATE100 Ex03 mode allows one keyboard and or one RS-232 scanner device in the EEx i area. The scanner must be connected to one of the mouse terminals at the hazardous side, this is still the case even if there is no keyboard. PS/2 and screw terminals for the hazardous area are wired in parallel.

#### **iSCAN100 RS232 Cable Connection Details**

<b>Description</b>	<b>Core Colour</b>
TxD	Green
Rxd	Yellow
GND	White
+5V Supply	Brown

### 3.3 Optional Accessory Kits

#### 3.3.1 Optional iSCAN100 Extender Junction Box – Part number iSCAN100JB

The iSCAN100 Extender Junction Box combines a junction box and wall mounting stand, allowing the iSCAN100 to be connected to the junction box in a hazardous area, and up to 50 metres of cable

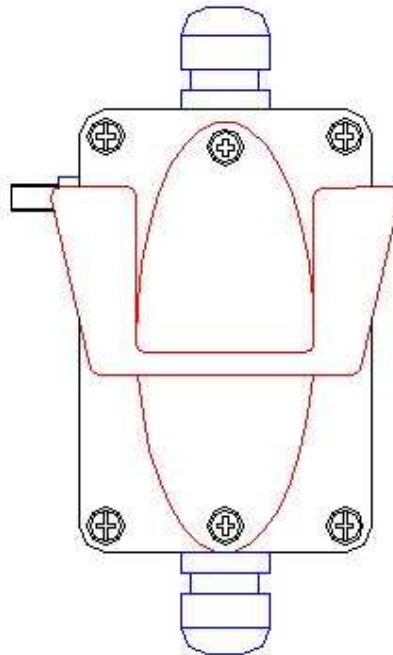

## Optional Wall Mount Hanger Kit #46-46508

### Contains:

- |    |                                    |       |
|----|------------------------------------|-------|
| a) | Wall mount hanger (MLPN 36-00611)  | Qty 1 |
| b) | Wall mount base (MLPN 36-00812)    | Qty 1 |
| c) | Self tapping screw (MLPN 18-18233) | Qty 2 |
| d) | Double sided tape                  | Qty 1 |
| e) | #8 wood screw                      | Qty 2 |

### Wall Mount, Option 1:

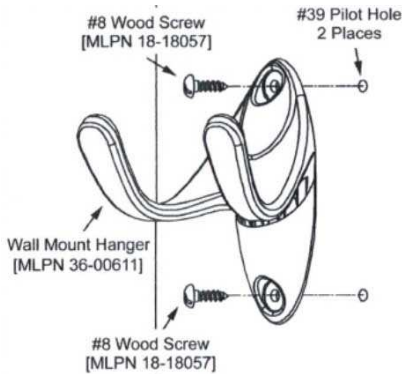

#### Step 1:

Drill two #39 pilot holes 3.00" apart.

#### Step 2:

Attach the *Wall Mount Hanger* to the wall with the two #8 wood screws provided.

### Wall Mount, Option 2:

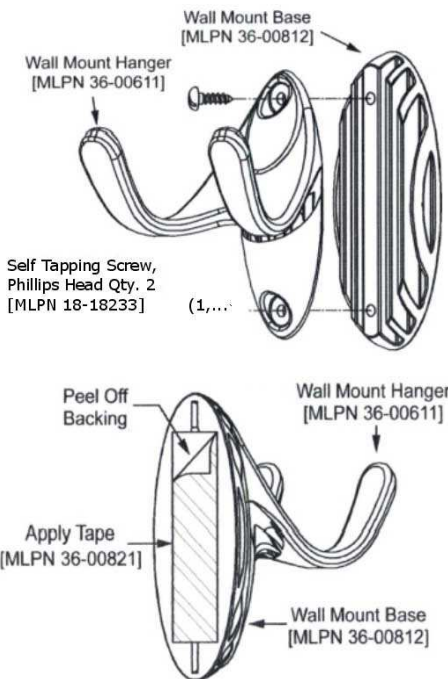

#### Step 1

Attach the Wall Mount Base to the Wall Mount Hanger with the two 4.8 x 13 mm self-tapping screws.

#### Step 2

Remove one side of the protective backing from the double-sided adhesive tape

#### Step 3

Attach the tape to the back of the wall mount base.

#### Step 4

Remove the remaining backing from the tape and attach to the wall.

---

## 4 Operation

---

### 4.1 How to use the iSCAN100

Aim the Scanner at the barcode and follow the instructions below

1 

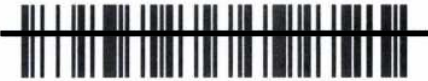
2 

3 

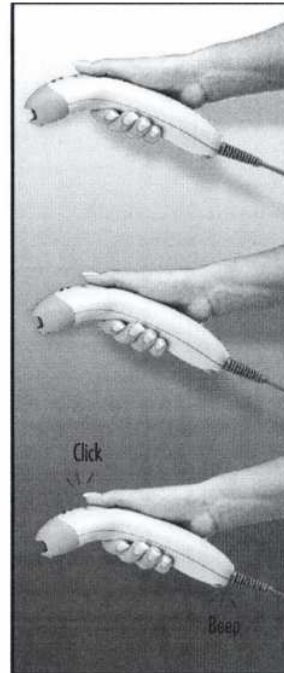

- Auto trigger activates the laser

- Place the laser line on the bar code

- Press the CodeGate button to transmit the data

## 4.2 Audible Indicators

---

When the iSCAN100 is in operation, it provides audible feedback. These sounds indicate the status of the scanner. Eight settings are available for the tone of the beep (normal, 6 alternate tones and no tone). To change the tone, refer to the MetroSelect® Single-Line Programming Guide included with the scanner. Alternatively see the help files contained in the MetroSet®2 help files.

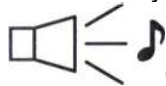

### **One Beep**

When the scanner *first* receives power, the green LED will turn on, then the red LED will flash and the scanner will beep once. (The red LED will remain on for the duration of the beep.) The scanner is ready to scan.

When the scanner *successfully* reads a bar code, the red LED will flash and the scanner beeps once (if programmed to do so). If the scanner does not beep once and the green light does not flash, then the bar code has *not* been successfully read.



### **Two Beeps — On Power Up**

When there is a Flash ROM upgrade needed, the scanner will beep twice followed by alternating flashing of the green and red LEDs.



### **Three Beeps - During Operation**

When entering configuration mode, the red LED will flash while the scanner simultaneously beeps three times. The red and green LEDs will continue to flash while in this mode. Upon exiting configuration mode, the scanner will beep three times, and the LEDs will stop flashing.

When configured, 3 beeps can also indicate a communications time-out during normal scanning mode.

When using one-code-programming, the scanner will beep three times (the current selected tone), followed by a short pause then by a high tone and a low tone. This tells the user that the single configuration bar code has successfully configured the scanner.



### **Raspberry Tone\Three Beeps - On Power Up**

This is a failure indicator. Refer to "Failure Modes" on page 14.

### 4.3 Visual Indicators

---

The iSCAN100 has three LED indicators (green, red and yellow) located on the head of the scanner. The MS9520 has two LED indicators (green and red) located on the head of the scanner. When the scanner is on, the flashing or stationary activity of the LEDs indicates the status of the current scan and the scanner.



#### **Green & red LED's off**

The LEDs will not be illuminated if the scanner is not receiving power from the host or transformer. The scanner is stand-by mode, and CodeGate® is enabled. Present a bar code to the scanner and the green LED will turn on when the laser turns on.



#### **Steady Green**

When the laser is active, the green LED is illuminated. The green LED will remain illuminated until the laser is deactivated. *(Default Mode Only)*



#### **Steady Green and Single Red Flash**

When the scanner successfully reads a bar code, the red LED will flash and the scanner will beep once. If the red LED does not flash or the scanner does not beep once, then the bar code has not been successfully read. *(Default Mode Only)*



#### **Steady Green and Steady Red**

After a successful scan, the scanner transmits the data to the host device. Some communication modes require that the host inform the scanner when data is ready to be received. If the host is not ready to accept the information, the scanner's red LED will remain on until the data can be transmitted.



#### **Alternating Flashing of Green and Red**

This indicates the scanner is program mode. A raspberry tone indicates that an invalid bar code has been scanned while in this mode.

The scanner needs to have a Flash ROM upgrade if the alternating flashing of the red and green LEDs occurs during start-up and is accompanied by three beeps.



#### **Steady Red, Green off**

This indicates the scanner may be waiting for communication from the host.

## **4.4 Failure Modes**

---

### **Flashing Green and one Raspberry Tone**

This indicates the scanner has experienced a laser sub-system failure. Return the unit for repair to an authorized service centre.

### **Flashing Red and Green with Two Raspberry Tones**

This indicates the scanner has experienced a scanning mechanism failure. Return the unit for repair to an authorized service centre.

### **Continuous Raspberry Tone with all LEDs off**

If, upon power up, the scanner emits a continuous raspberry tone, then the scanner has experienced an electronic failure. Return the unit for repair to an authorized service centre.

### **Three Beeps – on power up**

If the scanner beeps 3 times on power up then the non-volatile memory (NovRAM) that holds the scanner configuration has failed. If the scanner does not respond after reprogramming, return the scanner for repair to an authorized service center.

## 4.5 Programming Modes

The iSCAN100 has 3 modes of configuration.

- **Bar Codes**  
iSCAN100 can be configured by scanning the bar codes located in the MetroSelect® Single-Line Programming Guide supplied with the scanner. Please refer to this guide for instructions.
- **MetroSet® 2**  
This user-friendly Windows-based configuration program allows you to simply 'point-and-click' at the desired scanner options. This program can be downloaded for FREE from the following URL:  
[www.europe.metrologic.com/europe/download/software/metroset2install.exe](http://www.europe.metrologic.com/europe/download/software/metroset2install.exe).
- **Serial Programming**  
This mode of programming is ideal for OEM applications. This mode gives the end-user the ability to send a series of commands using the serial port of the host system. The commands are equivalent to the numerical values of the bar codes located in the MetroSelect Single-Line Programming Guide supplied with the scanner.

## 4.6 Serial Programming

Each command sent to the scanner is the ASCII representation of each numeral in the configuration bar code. The entire numeric string is framed with an ASCII [stx] and an ASCII [etx].

### EXAMPLE #1:

Command for Disabling Codabar Command = [stx]100104[etx]

String Sent to Scanner = 02h 31h 30h 30h 31h 30h 34h 03h

(All values are hexadecimal).

If the command sent to the scanner is valid, the scanner will respond with an [ack].

If the command sent to the scanner is invalid, the scanner will respond with a [nak].

**NOTE:** If this occurs, the end-user must start over at the very beginning of the configuration sequence. Simply re-transmitting the invalid command will not work, you must start over.

During programming, the motor and laser turn off. **YOU CANNOT SCAN A BAR CODE WHILE IN SERIAL PROGRAM MODE.**

There is a 20 second window between commands. If a 20 second time-out occurs, the scanner will send a [flak] and you must start over.

To enter serial program mode, send the following command [stx]999999[etx].

To exit serial program mode, send the following command [stx]999999[etx], the scanner will respond with an [ack] followed by 3 beeps.

This mode uses the current Baud Rate, Parity, Stop Bits and Data Bits settings that are configured in the scanner. The default settings of the scanner are 9600, Space, 2, 7 respectively. If a command is sent to the scanner to change any of these settings, the change will NOT take effect until after serial program mode is exited.

EXAMPLE #2:

The following example will set the scanner to the factory default settings, Disable Scanning of Code 128 bar codes, change the beeper tone, and add a "G" as a programmable prefix.

FEATURE	HOST COMMAND	ASCII REPRESENTATION	SCANNER RESPONSE
Enter Program Mode	[stx]999999[etx]	02h 39h 39h 39h 39h 39h 39h 03h	[ack] or 06h
Load Defaults	[stx]999998[etx]	02h 39h 39h 39h 39h 39h 38h 03h	[ack] or 06h
Disable Code 128	[stx]100113[etx]	02h 31h 30h 30h 31h 31h 33h	[ack] or 06h
Alternate Tone 1	[stx]318565[etx]	02h 33h 31h 38h 35h 36h 35h 03h	[ack] or 06h
Prog. Prefix #1	[stx]903500[etx]	02h 39h 30h 33h 35h 30h 30h 03h	[ack] or 06h
Code Byte 0	[stx]0[etx]	02h 30h 03h	[ack] or 06h
Code Byte 7	[stx]7[etx]	02h 37h 03h	[ack] or 06h
Code Byte 1	[stx]1[etx]	02h 31h 03h	[ack] or 06h
Exit Program Mode	[stx]999999[etx]	02h 39h 39h 39h 39h 39h 39h 03h	[ack] or 06h

The scanner will beep three times!

The commands sent to the scanner do not include the small superscripted `3' that you see in front of each bar code string in the MetroSelect manual. THE '3' SHOULD NOT BE SENT, IT IS A CODE TYPE DESIGNATION ONLY!

As you will note for commands requiring additional bar codes to be scanned (such as prefixes, suffixes, time-outs, etc.), simply send the code bytes in the same order that you would normally scan the bar codes.

### EXAMPLE #3:

The following example shows the events that occur when an invalid bar code is sent. This sample will load the factory default settings and then set the baud rate to 19200.

FEATURE	HOST COMMAND	ASCII REPRESENTATION	SCANNER RESPONSE
Enter Program Mode	[stx]999999[etx]	02h 39h 39h 39h 39h 39h 39h 03h	[ack] or 06h
Load Defaults	[stx]99999:[etx]	02h 39h 39h 39h 39h 39h 3Ah 03h	[nak] or 15h
Invalid command was sent, you must start over!			[ack] or 06h
Enter Program Mode	[stx]999999[etx]	02h 39h 39h 39h 39h 39h 39h 03h	
Load Defaults	[stx]999998[etx]	02h 39h 39h 39h 39h 39h 39h 03h	[ack] or 06h
19200 Baud Rate	[stx]415870[etx]	02h 34h 31h 35h 38h 37h 30h 03h	[ack] or 06h
Exit Program Mode	[stx]999999[etx]	02h 39h 39h 39h 39h 39h 39h 03h	[ack] or 06h

The scanner will beep three times!

This example illustrates two important points.

First, if an invalid command is sent from the host, the scanner responds with a [nak] and the end-user must start over from the beginning.

Second, if a command is sent to change the Baud Rate, the new baud rate does not take effect until after the end-user exits program mode.

### ABBREVIATED ASCII TABLE

Character	Hex Value	Decimal Value
[SIX]	02h	2
[ETX]	03h	3
[ACK]	06h	6
[NAK]	15h	21
0	30h	48
1	31 h	49
2	32h	50
3	33h	51
4	34h	52
5	35h	53
6	36h	54
7	37h	55
8	38h	56
9	39h	57

## 4.7 Upgrading The Flash ROM Firmware

The **Meteor** program is a functional component of Extronics new line of Flash-based scanners. This program allows the user of Extronics scanner to quickly upgrade to a new or custom version of software. It requires the use of a personal computer running under Windows 95 or greater and the use of a communication port. The user merely connects the scanner to a communications port of the PC, launches the **Meteor** program, and blasts off to new software upgrades.

Each MS9500, regardless of the version number or communication protocol, can be upgraded. In other words, all RS232 (-41), keyboard wedge (-47), light pen (-41), laser emulation (-00), OCIA (-9) and IBM 468X/469X (-11) units can be upgraded. To upgrade all units, a power supply and PowerLink cable (MLPN 54-54012) are required.

The upgrades and custom software versions will be supplied by Extronics in files called Motorola S-record files. These files contain all the information needed to upgrade the scanner. Simply add this file to the working directory or retrieve from its current location.

The program guides the user with its simplistic one click approach. The user must first select the file; once selected and verified, the file is ready to be used in the upgrade. Press the button to upgrade the scanner, the unit will go into a "flash mode" — both the green and red LEDs will be on. The user can follow the progress of the upgrade by watching the screen for details. When the upgrade is complete, the scanner will respond with its normal one beep on power up. If two beeps occur, the scanner did not upgrade properly. (Contact an Extronics for additional details).

## 5 Depth of Field and IR Activation

### DEPTH OF FIELD

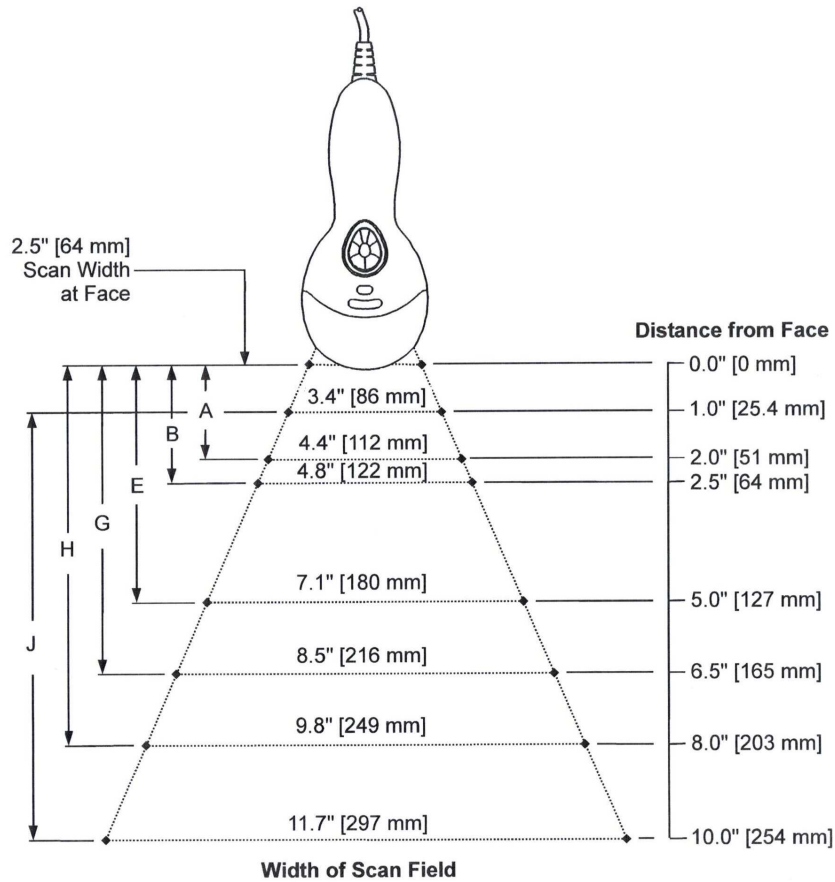

Minimum Bar Code Element Width										
Code Element										
Width	A	B	C	D	E	F	G	H	J	K
mm	0.13	0.15			0.19		0.25	0.33	0.53	-
mils	5.2	5.7			7.5		10	13	21	

# IR ACTIVATION

---

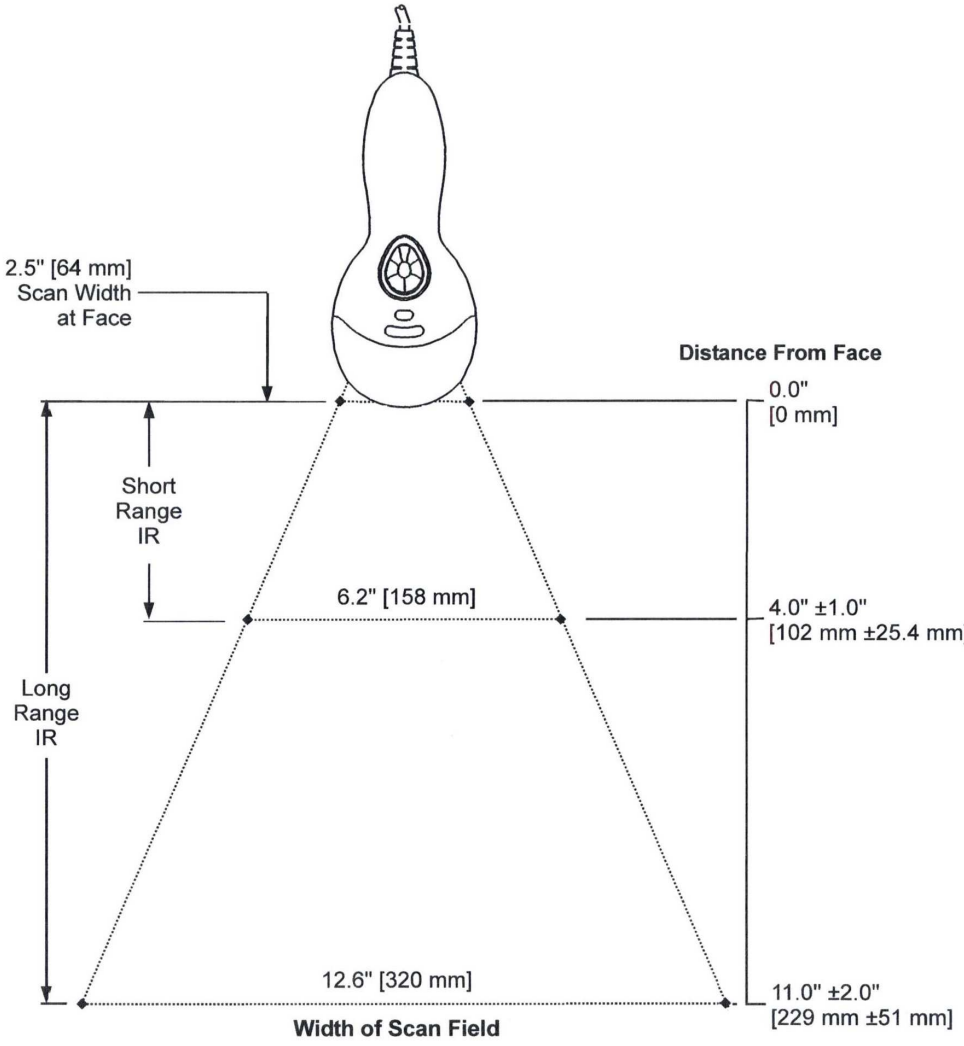

## 6 Troubleshooting Guide

All Interfaces

<b>iSCAN100 Series Troubleshooting Guide</b>		
<b>Symptoms</b>	<b>Possible Causes</b>	<b>Solution</b>
No LEDs, beep or laser	No power is being supplied to the Scanner	Check transformer, outlet and power strip. Make sure the cable is plugged into the scanner.
No LEDs, beep, or laser	No power is being supplied to the scanner from host	Some host systems cannot supply enough current to power Voyager. A power supply may be needed.
2 Beeps with alternately flashing LEDs on Power up	Possible ROM failure	Flash ROM Upgrade Required
3 Beeps on power up	Non-volatile RAM failure	Contact an Extronics Representative, if the unit will not hold the programmed configuration.
Continuous razz tone on power up	RAM or ROM failure	Contact an Extronics Representative, if the unit will not function.
Razz tone and green LED flash at power up	VLD failure	Contact an Extronics Representative
Razz tone, red and green LEDs flash at power up	Scanning mechanism failure	Contact an Extronics Representative
Unit scans, Communicates and beeps twice	Same symbol time-out set too short	Adjust same symbol time-out for a longer time.
The unit powers up, but does not scan/or beep	Beeper disabled. No tone selected	Enable beeper. Select tone.

<b>Symptoms</b>	<b>Possible Causes</b>	<b>Solution</b>
The unit powers up, but does not scan and/or beep	Scanning a particular symbology that is not enabled	UPC/EAN, Code 39, interleaved 2 of 5, Code 93, Code 128 and Codabar are enabled by default. Verify that the type of bar code being read has been selected.
The unit powers up, but does not scan and/or beep	The scanner has been programmed for a character length lock, or a minimum length and bar code being scanned does not satisfy the programmed criteria	Verify that the bar code that is being scanned falls into the criteria Typical of Non-UPC/EAN codes) The scanner defaults to a minimum of 3 character bar code.
The unit scans a bar code, but locks up after the first scan red LED stays on	The scanner is configured to support some form of host handshaking but is not receiving the signal	If the scanner is setup to support ACK/NAK, RTS/CTS, XON/XOFF or D/E, verify that the host cable and host are supporting the handshaking properly.
The unit scans, but the data transmitted to the host is incorrect	The scanner's data format does not match the host system requirements	Verify that the scanner's data format matches that required by the host. Most sure that the scanner is connected to the proper host port.
Scanner beeps at some bar codes and NOT for others of the same bar code symbology	The print quality of the bar code is suspect	Check print mode. The type of printer could be the problem. Change print settings. i.e. change to econo mode or high speed.
Scanner beeps at some bar codes and NOT for others of the same bar code symbology	The aspect ratio of the bar code is out of tolerance	Check print mode. The type of printer could be the problem. Change print settings. i.e. change to econo mode or high speed.

<b>Symptoms</b>	<b>Possible Causes</b>	<b>Solution</b>
Scanner beeps at some bar codes and NOT for others of the same bar code symbology	The bar code may have been printed incorrectly	Check if it is a check digit/character/or border problem.
Scanner beeps at some bar codes and NOT for others of the same bar code symbology	The scanner is not configured correctly for this type of bar code	Check if check digits are set properly.
Scanner beeps at some bar codes and NOT for others of the same bar code symbology	The minimum symbol length setting does not work with the bar code	Check if the correct minimum symbol length is set.
The unit scans the bar code but there is no data	Configuration is not correct	Make sure the scanner is configured for the appropriate mode.
The unit scans but the data is not correct	Configuration is correct	Make sure that the proper PC type AT, PS2 or XT is selected. Verify correct country code and data formatting are selected. Adjust inter-character delay symptom.
The unit is transmitting each character twice	Configuration is not correct	Increase interscan code delay setting. Adjust whether the FO break is transmitted. It may be necessary to try this in both settings.

<b>Symptoms</b>	<b>Possible Causes</b>	<b>Solution</b>
Alpha characters show as lower case	Computer is in Caps Lock mode	Enable Caps Lock detect setting of the scanner to detect whether the PC is operating in Caps Lock.
Everything works except for a couple of characters	These characters may not be supported by that country's key look up table	Try operating the scanner in Alt mode.
Power-up OK and scans OK but does not communicate properly to the host	Corn port at the host is not working or configured properly	Check to make sure that the baud rate and parity of the scanner and the communication port match and the program is looking for "RS-232" data.
Power-up OK and scans OK but does not communicate properly to the host	Cable not connected to the proper corn port	Check to make sure that the baud rate and parity of the scanner and the communication port match and the program is looking for "RS-232" data.
Power-up OK and scans OK but does not communicate properly to the host	Cable not connected to the proper corn port	Check to make sure that the baud rate and parity of the scanner and the communication port match and the program is looking for "RS-232" data.
The host is receiving data but the data does not look correct	The scanner and host may not be configured for the same interface parameters	Check that the scanner and the host are configured for the same interface parameters
Characters are being dropped	Inter-character delay needs to be added to the transmitted output	Add some inter-character delay to the transmitted output by using the MetroSelect Single-Line Programming Guide MLPN 00-02544.

---

## 7 Intended Purpose Usage

---

**Important** Before setting the units to work, read the technical documentation carefully.

**Important** The latest version of the technical documentation or the corresponding technical supplements is valid in each case.

The iSCAN100 is built using modern components and is extremely reliable in operation; however it must only be used for its intended purpose. Please note that the intended purpose also includes compliance with the instructions issued by the manufacturer for installation, setting up and service.

Any other use is regarded as conflicting with the intended purpose. The manufacturer is not liable for any subsequent damage resulting from such inadmissible use. The user bears the sole risk in such cases.

### **Transportation and Storage**

All iSCAN100 devices must be so transported and stored that they are not subjected to any excessive mechanical stresses.

### **Authorized Persons**

Only persons trained for the purpose are authorized to handle the iSCAN100; they must be familiar with the unit and must be aware of the regulation and provisions required for explosion protection as well as the relevant accident prevention regulations.

### **Cleaning and Maintenance**

The iSCAN100 and all its components require periodic inspection. All work on the iSCAN100 by personnel who are not expressly qualified for such activities will cause the Ex approval and the guarantee to become void.

The scanner may be cleaned with a damp cloth or a brush. The laser window may be cleaned from periodically with a very soft cloth. The scanner must not be cleaned within the Ex area due to potential charging of the cleaning tool

The protective conducting layer must not be damaged. If there is visible damage of significant areas of the layer the scanner must not be used inside of Ex areas until it has been repaired by the manufacturer

**Safety Precautions**

Important For the installation, maintenance and cleaning of the units, it is absolutely necessary to observe the applicable regulations and provisions concerned with explosion protection (EN 50014, EN 60079-14:2003) as well as the Accident Prevention Regulations.

**Cleaning and Maintenance Intervals**

The cleaning intervals depend on the environment where the system is installed.

**Aggressive substances and environments**

The iSCAN100 is not designed to come into contact with aggressive substances or environments, please be aware that additional protection may be required.

**Exposure to external stresses**

The iSCAN100 is not designed to be subjected to excessive stresses e.g. vibration, heat, impact. Additional protection is required to protect against these external stresses.

The iSCAN100 will require additional protection if it is installed in a location where it may be subjected to damage

---

## 8 Technical Data

---

<b>Power Supply</b>	Via ISOLATE100 and powered from the PS2 port on the PC, or by the designated socket on your Challenger terminal. For RS232 version please Contact an Extronics.
<b>Electrical Connection</b>	270 cm coiled lead
<b>Interface</b>	RS232 or PS2 keyboard wedge
<b>Barcode Compatibility</b>	Auto discriminates all standard bar codes. For other Symbologies please call Extronics. Automatic Trigger
<b>Weight</b>	149 g
<b>Scan System</b>	Laser diode, 650 nm friction free mechanism
<b>Scanning Range</b>	279mm max +/- 51mm
<b>Material</b>	Plastic housing with protective rubber shield
<b>Dimensions</b>	198mm x 102mm x 40mm (h x w x d)
<b>Ambient Temperature</b>	-20°C to +40°C
<b>IP Rating</b>	IP55
<b>Certification Type</b>	TUV 02 ATEX 1823
<b>Certification Number</b>	II 2GD EEx ib IIC T4

## **MECHANICAL**

Length: 198 mm (7.8")

Width: Handle - 45 mm (1.8"), Head - 78 mm (3.1") Depth: 40 mm (1.6")

Weight: 149 g (5.25 oz)

## **ELECTRICAL**

Input Voltage: 5VDC  $\pm$  0.25V

### **Power**

Operating = 0.825 W

Standby = 0.600 W

### **Current**

Operating = 165 mA @ 5VDC

Standby = 120 mA @ 5VDC

DC Transformers: ? Class 2; 5.2V @ 650 mA

### **Laser Class**

CDRH: Class II; **EN60825-1:1994/A11:1996 Class 1** EMC: FCC Class B

## **ENVIRONMENTAL**

Intended operating temperature range- 0 to 40°C (32 to 104°F)

Temperature: Storage = -40 to 60°C (-40 to 140°F)

Humidity - 5% to 95% relative humidity, non-condensing Light Levels: Up to 4842

Lux (450 footcandles)

Shock - Designed to withstand 1.5 m (5') drops

Contaminants - Sealed to resist airborne particulate contaminants

Ventilation - None required

## **OPERATIONAL**

Light Source: Visible Laser Diode 650 nm  $\pm$  10 nm Laser Power: Less than 1 mW (peak)

Depth of Scan Field: 0 mm — 203 mm (0" — 8") for 0.330 mm (13 mil) bar code at default setting

Scan Speed: 72 scan lines per second Scan Pattern: Single scan line Minimum Bar Width: 0.127 mm (5.0 mil)

Infrared Activation: Long Range: 0 mm — 279 mm  $\pm$  51 mm (0" — 11"  $\pm$  2") Short

Range: 0 mm — 102 mm  $\pm$   
25 mm (0" — 4"  $\pm$  1")

Print Contrast: 35% minimum reflectance difference

Number Characters Up to 80 data characters

Read: (Maximum number will vary based on symbology & density) Roll, Pitch,

Yaw: 42°, 68°, 52°

Beeper Operation: 7 tones or no beep

Indicators (LED) Green = laser on, ready to scan; Red = good

---

## 9 Certification

---

### EC Declaration of Conformity



We hereby confirm the conformity of the equipment listed below with the directives of the Council of the European Community. The safety and installation instructions of the product documentation must be observed.

Model: **iSCAN100**

Directive: EMC Directive 98/336/EC\*  
European standard: EN 55022: 1998, class B  
EN 55024: May 1999

Directive: Low Voltage Directive 73/23/EC\*

European standard: EN60950\*  
EN 60825-1\* (Laser)

Directive: 94/9/EC

European Standards: EN 50014: 02/2000\*  
EN 50020: 2002  
EN 50028: 07/1988  
EN 50281-1-1: 11/2003

\* including amendments

Extronics Limited  
Meridian House  
Roe Street  
Congleton  
CW12 1PG  
01260 292652  
[www.extronics.com](http://www.extronics.com)

ATEX Label Format

RS-232, G + D

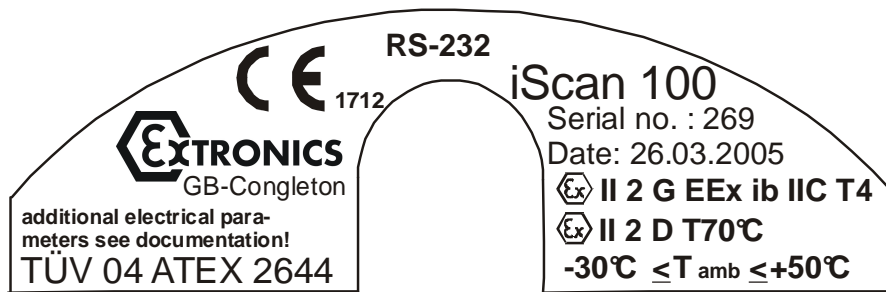

---

## **10 Booklet Revision Notes**

---

First issue – Issue 1 – August 2007