

# MINI HAWK SERIES



**Compact Shape/Size**

**ACTUAL SIZE SHOWN**  
 Height: 1" (25.4 mm)  
 Width: 1.80" (45.7 mm)  
 Length: 2.10" (53.3 mm)

**X-Mode Technology**

**Wide Field of View, Autofocus**



## Mini Imagers for Direct Part Marks

MINI Hawk imagers pack aggressive direct part mark (DPM) reading algorithms into a miniature imager that is both powerful and easy to use for barcode and 2D track, trace and control applications. Aggressive decoding is ensured through X-Mode technology, which reads damaged or difficult symbols with no configuration or setup required.

With high speed and high resolution configurations available, there is a MINI Hawk imager to solve virtually any challenging application.

### MINI Hawk Series: At a Glance

- Decode speed and read range: Varies by model
- X-Mode Decoding Technology
- Autofocus
- Optional USB Connectivity

**MINI HAWK HR:** High resolution imager

**MINI HAWK HS:** High speed imager



ESP® Easy Setup Program: Single-point software provides quick and easy setup and configuration of all Microscan readers.



EZ Button: This performs reader setup and configuration with no computer required.



Visible Indicators: Include "good read" green flash, LEDs and symbol positioning tool.

For more information on this product, visit [www.microscan.com](http://www.microscan.com).

#### Decode Any Symbol

The MINI Hawk consistently reads damaged, distorted or otherwise challenging direct part marks with our patented decode algorithms.

#### Autofocus

For real time dynamic autofocus, position the symbol at the center of the field of view, and push the EZ button. The MINI Hawk automatically adjusts focal distance and sets internal parameters to optimize the symbol.

#### Wide Field of View

Read symbols as large as 2" (50.8 mm) square as close as 1" (25.4 mm) with diffractive field illumination and optional right angle mirror.

#### X-Mode Technology

In addition to the most aggressive decoding available, X-Mode technology provides easy setup and deployment of the MINI Hawk in any application.

#### Compact and Lightweight

Miniature form factor fits easily in tight spaces, and is lightweight for mounting into robotic applications.

#### Application Examples

- Automotive
- Dot peen mark on power-train components
  - Laser marks on automotive electronics components
- Medical Devices
- Laser marks on components
- Electronics
- Laser markings on printed circuits boards, flex circuits
- Semiconductors
- Laser marks on packages and components

### MINI Hawk Series: Available Codes



# MINI HAWK SERIES SPECIFICATIONS AND OPTIONS

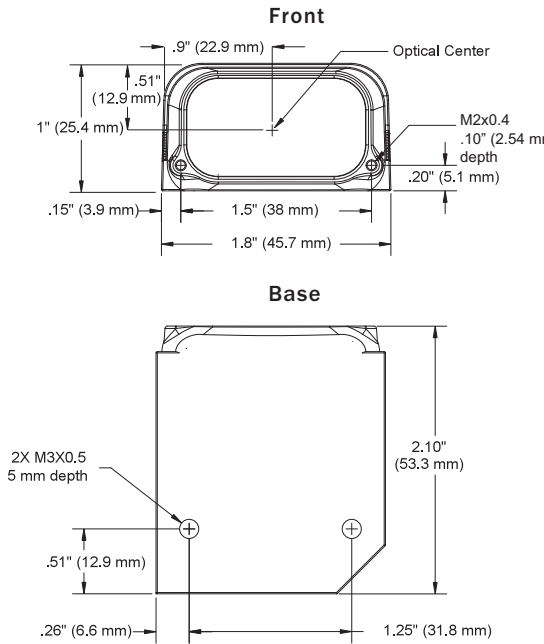

## READ RANGES (GRAPHS AND TABLES)

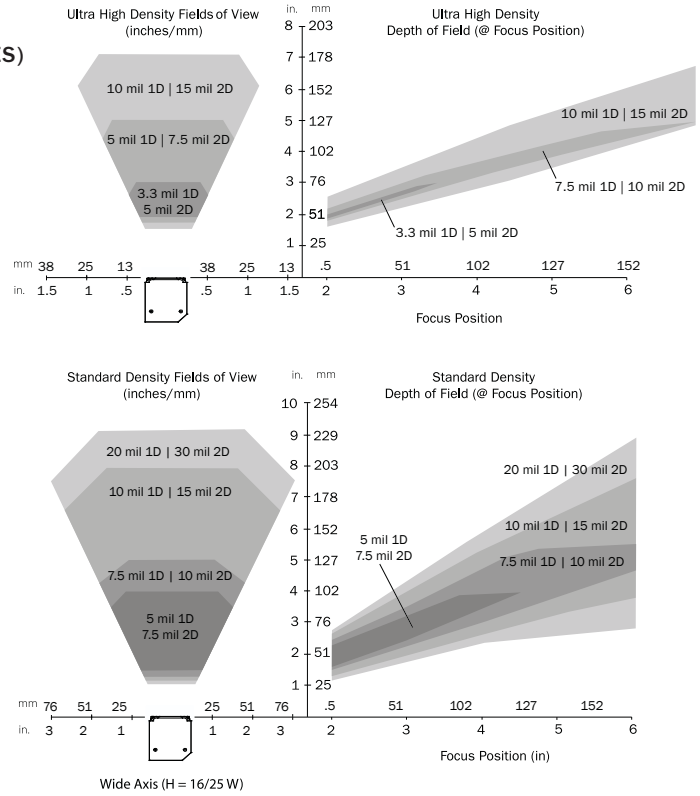

### MECHANICAL

**Height:** 1" (25.4 mm) **Width:** 1.80" (45.7 mm)  
**Depth:** 2.10" (53.3 mm) **Weight:** 2-oz (57 g)

### ENVIRONMENTAL

**Enclosure:** IP54 (category 2)  
**Humidity:** up to 90% (non-condensing)  
**Operating Temperature:** 0° to 40°C (32° to 104°F)  
**Storage Temperature:** -50° to 75° C (-58 to 167°F)

### CE MARK

EN 55024: 1998 ITE Immunity Standard  
 EN 55022:98 ITE Disturbances

### LIGHT SOURCE

**Type:** High output LEDs

### LIGHT COLLECTION OPTIONS

Progressive scan, square pixel. Software adjustable shutter speed, electronic shutter

**MINI HAWK HR:** 1280 by 1024 pixels (SXGA)

**MINI HAWK HS:** 752 by 480 pixels (WVGA)



### SYMBOLGY TYPES

**2D Symbolgies:** Data Matrix, QR Code, Micro QR Code

**Stacked Symbolgies:** PDF417, Micro PDF417, GS1 Databar (Composite & Stacked)

**Linear Bar Codes:** Code 39, Code 128, BC 412, I2 of 5, UPC/EAN, Codabar, Code 93

### READ PARAMETERS

**Pitch:** ±30° **Skew:** ±30° **Tilt:** 360°  
**Decode Rate:** Up to 60 decodes per second (HS model)  
**Focal Range:** 1.3 to 9.3" (33 to 236 mm) (autofocus)

### CONNECTOR

**Type:** 3 ft. cable terminated with High Density 15-pin D-Sub socket connector or USB Type A connector

### INDICATORS

**LEDs:** Read Performance, Power, Read Status  
**Green Flash:** Good read **Blue V:** Symbol locator  
**Beeper:** Good read, match/mismatch, noread, serial command confirmation, on/off

### COMMUNICATION PROTOCOLS

**Standard Interface:** RS-232, RS-422, or USB

### ELECTRICAL

**Power:** 5 VDC +/- 5%, 200 mV p-p max. ripple, 494 mA @ 5 VDC (typ.)  
**Optional Int.:** 10-28 V Accessory

Narrow-bar-width		Field of View (maximum)	Read Range (using autofocus)
1D	2D		
<b>Ultra High Density</b>			
.0033" (0.08 mm)	.005" (.13 mm)	1.1" (29 mm)	1.9 to 3.0" (48 mm to 76 mm)
.005" (0.13 mm)	.075" (.19 mm)	1.8" (45 mm)	1.8 to 5.0" (46 mm to 127 mm)
.010" (0.25 mm)	.15" (.38 mm)	2.5" (64 mm)	1.6 to 7.0" (41 mm to 178 mm)
<b>Standard Density</b>			
.005" (0.13 mm)	.0075" (.19 mm)	2.7" (69 mm)	1.7 to 3.4" (43 mm to 86 mm)
.0075" (0.19 mm)	.010" (.25 mm)	3.7" (93 mm)	1.6 to 5.0" (41 mm to 127 mm)
.010" (0.25 mm)	.15" (.38 mm)	4.7" (118 mm)	1.4 to 8.0" (36 mm to 203 mm)
.020" (0.51 mm)	.030" (.76 mm)	5.3" (136 mm)	1.3 to 9.3" (33 mm to 236 mm)

**MINI HAWK HS units used for data collection. Data subject to change.**

### HOST CONNECTOR/PIN ASSIGNMENTS

#### High Density 15 Pin D-sub Socket Connector

Pin No.	Host RS232	Host/Aux RS232	Host RS422/485	In/Out
1	Power +5 VDC			In
2	TxD	TxD	TxD(-)	Out
3	RxD	RxD	RxD(-)	In
4	Power/Signal Ground			
5	NC			
6	RTS	Aux TxD	TxD(+)	Out
7	Output 1 TTL <sup>a</sup>			Out
8	Default configuration <sup>b</sup>			In
9	Trigger			In
10	CTS	Aux RxD	RxD (+)	In
11	Output 3 TTL <sup>a</sup>			Out
12	New Master (NPN)			In
13	Chassis ground <sup>c</sup>			
14	Output 2 TTL <sup>a</sup>			Out
15	NC			

a. Can sink 10 mA and source 10 mA.  
 b. The default is activated by connecting pin 8 to ground pin 4.  
 c. Chassis ground: Used to connect chassis body to earth ground only. Not to be used as power or signal return.

### DISCRETE I/O

**Trigger Input:** 5 to 28 VDC rated (.16 mA)  
**New Master:** 5 to 28 VDC rated (.16 mA)  
**Outputs (1, 2, 3):** 5V TTL compatible, can sink 10 mA and source 10mA  
**Optional I/O:** Optoisolated (with IC-332 accessory)

### SAFETY CERTIFICATIONS DESIGNED FOR

FCC, UL/cUL, CE, CB

### ROHS/WEEE COMPLIANT

### ISO CERTIFICATION

Issued by TÜV USA Inc, Member of TÜV NORD Group, Cert No. 06-1080

©2009 Microscan Systems, Inc. SP057A 02/09  
 Read Range and other performance data is determined using high quality Grade A symbols per ISO/IEC 15415 and ISO/IEC 15416 in a 25°C environment. For application-specific Read Range results, testing should be performed with symbols used in the actual application. Microscan Applications Engineering is available to assist with evaluations. Results may vary depending on symbol quality. **Warranty**—One year limited warranty on parts and labor. Extended warranty available.

# MICROSCAN®

### Microscan Systems Inc.

Tel 425 226 5700 / 800 251 7711  
 Fax 425 226 8250

### Microscan Europe

Tel 31 172 423360 / Fax 31 172 423366

### Microscan Asia Pacific

Tel 65 6846 1214 / Fax 65 6846 4641

### www.microscan.com

Product Information: info@microscan.com  
 Auto ID Support: helpdesk@microscan.com  
 Vision Support: visionsupport@microscan.com  
 NERLITE Support: nerlitesupport@microscan.com